

Specifications - Adjustable Spindle Drill Heads

ADJUSTABLE TWO SPINDLE DRILL HEAD

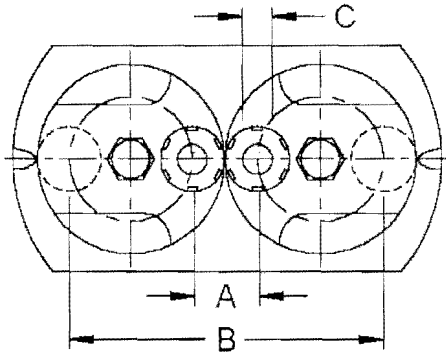

MODEL	A (MIN C-C)		B (MAX C-C)		C (MAX DIA)	
	in	mm	in	mm	in	mm
2-5	.532	13.5	2.89	73.5	3/16	5
2-7	.71	18	3.54	90	1/4	7
2-10	.867	22	4.17	106	3/8	10
2-16	1.42	36	6.45	164	5/8	16

ADJUSTABLE IN-LINE THREE SPINDLE DRILL HEAD

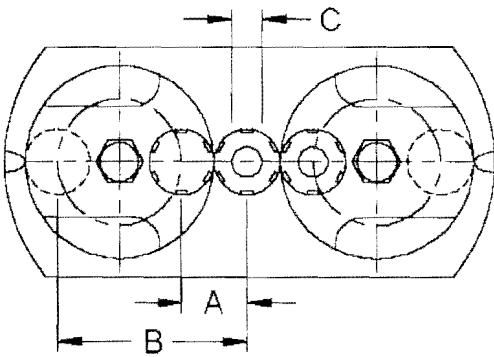

MODEL	A (MIN C-C)		B (MAX C-C)		C (MAX DIA)	
	in	mm	in	mm	in	mm
3L-5	.552	14	1.73	44	3/16	5
3L-7	.788	20	2.20	56	1/4	7
3L-10	.867	22	2.52	64	3/8	10
3L-16	1.42	36	3.93	100	5/8	16

ADJUSTABLE BOLT CIRCLE THREE SPINDLE DRILL HEAD

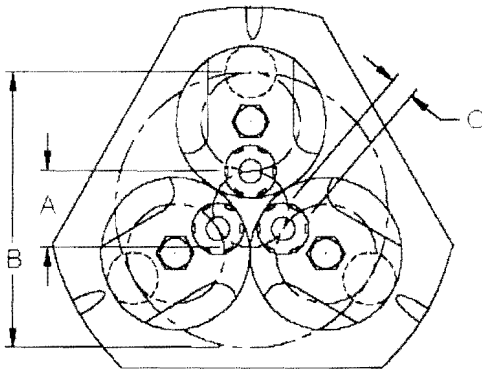

MODEL	A (MIN C-C)		B (MAX C-C)		C (MAX DIA)	
	in	mm	in	mm	in	mm
3C-5	.887	22	3.22	82	3/16	5
3C-7	1.10	28	3.93	100	1/4	7
3C-10	1.26	32	4.56	116	3/8	10
3C-16	2.04	52	7.08	180	5/8	16

ADJUSTABLE BOLT CIRCLE FOUR SPINDLE DRILL HEAD

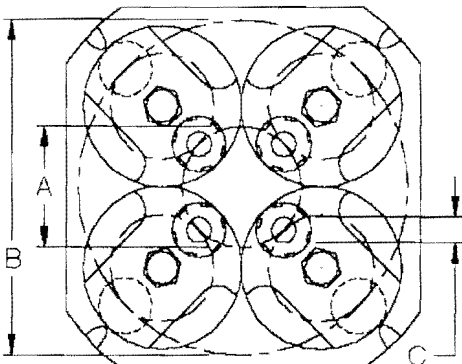

MODEL	A (MIN C-C)		B (MAX C-C)		C (MAX DIA)	
	in	mm	in	mm	in	mm
4C-5	1.33	34	3.70	94	3/16	5
4C-7	1.65	42	4.48	114	1/4	7
4C-10	1.89	48	5.19	132	3/8	10
4C-16	3.07	78	8.11	206	5/8	16